

High Voltage Linear Regulator

REV: 03

General Description

The LD6902 is a high voltage, micropower linear regulator, which features wide input voltage, low-noise, low-dropout and low-quiescent current. The precision of feedback reference voltage is within $\pm 2\%$ and output current is up to 90mA.

The LD6902 can also be used as a WLED driver. The external soft start function provides a flexible way to limit the startup current.

Features

- $\pm 2\%$ feedback reference
- Shutdown current $< 1\mu\text{A}$ (TYP)
- High input voltage: up to 21V
- Thermal shutdown and current limit protection
- Soft start operation

Applications

- Microcontroller Power
- Hand-Held Instruments

+Patent pending

Typical Application

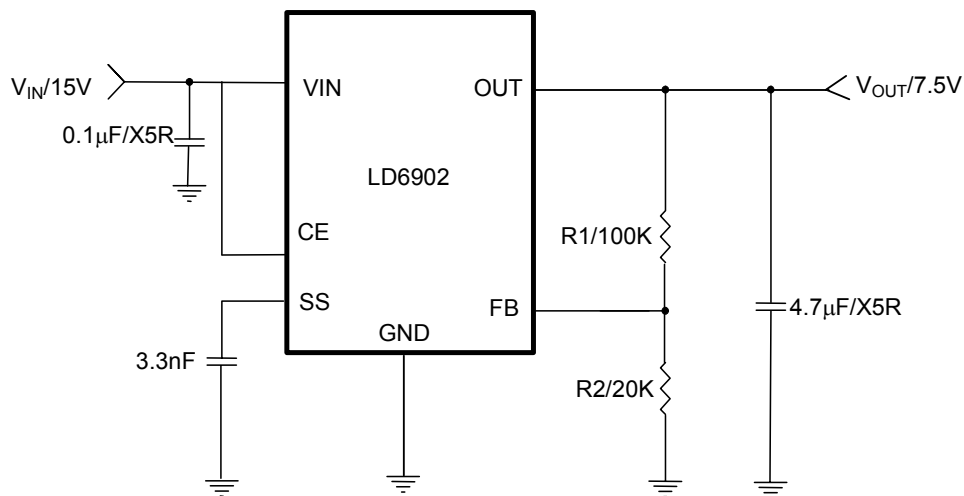
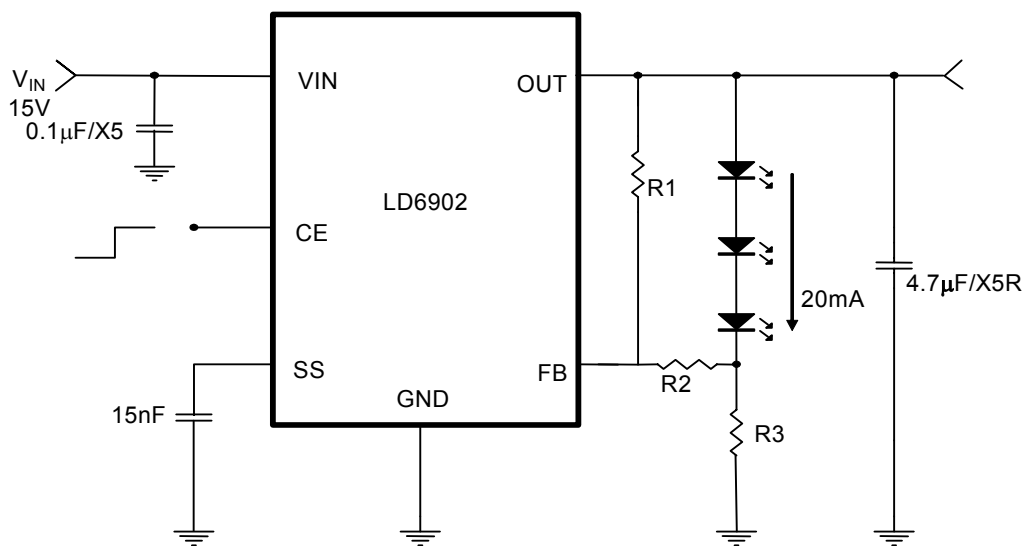
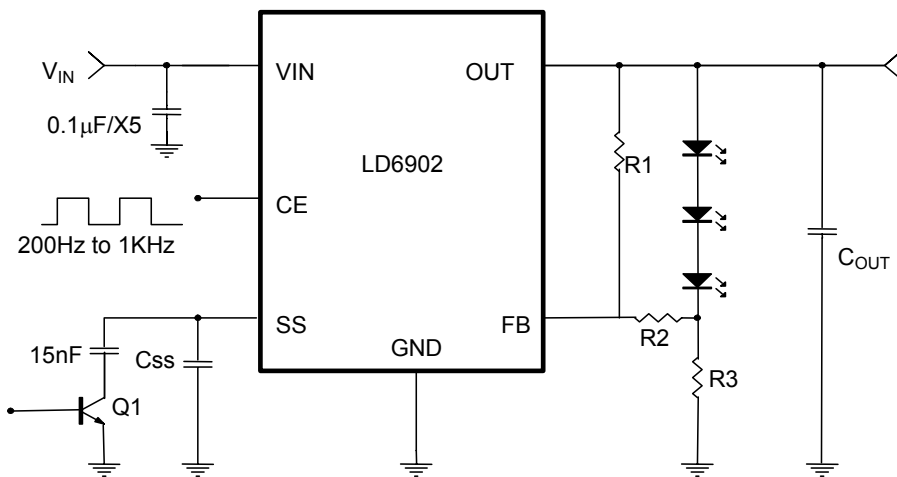

Fig.1 High voltage linear regulator application



	2 WLED	3 WLED
R1	62K	62K
R2	3.24K	2K
R3	47.5Ω	47.5Ω

Fig.2 WLED driver application



To avoid inrush current during the first start up cycle, please turn on Q1 at the first CE pin pulse and then turn off Q1.

Fig.3 WLED driver application

Pin Configuration

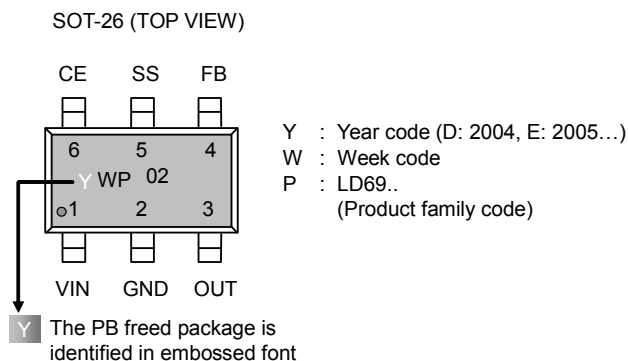

Ordering Information

Part number	Package	TOP MARK	Shipping
LD6902 PL	SOT-26 (PB FREE)	YWP/02	3000 /tape & reel
LD6902 GL	SOT-26 (Green Compound)	YWP/02	3000 /tape & reel

Pin Descriptions

PIN	NAME	FUNCTION
1	VIN	Input Voltage
2	GND	IC GND
3	OUT	Regulator Output
4	FB	Output Feedback
5	SS	This pin combines noise bypass and soft start function. Connect a capacitor to GND to adjust soft start time.
6	CE	Chip Enable, High=Enable, Low=Disable, Note that this pin is high impedance. There should be a pull low resistor connected to GND, when this pin is floating.

Block Diagram

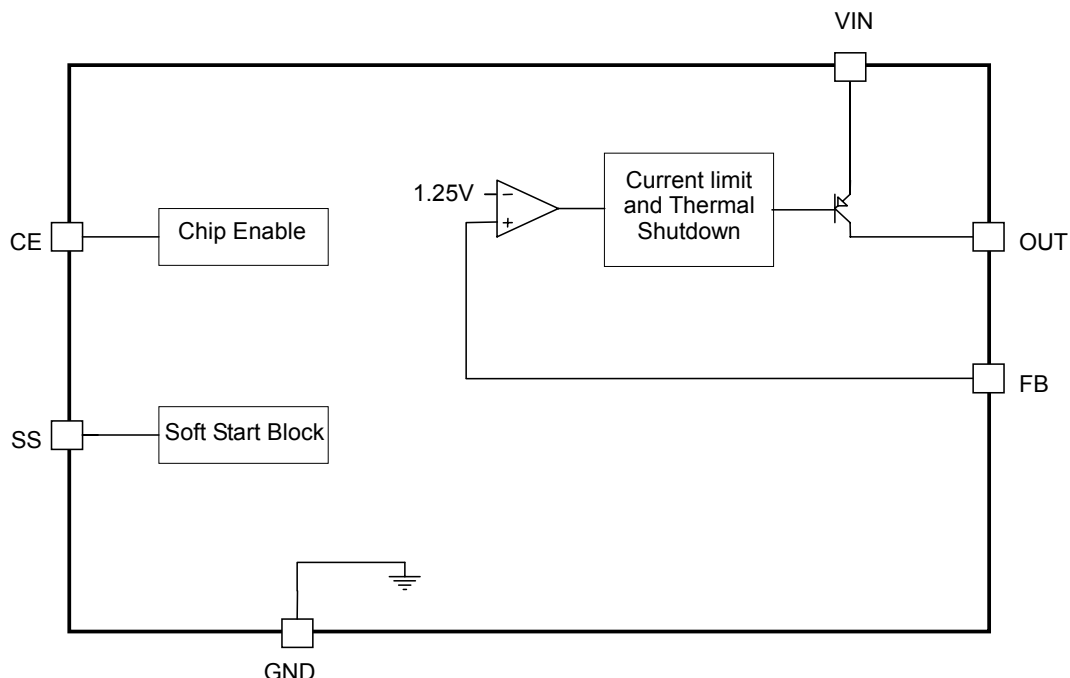

Absolute Maximum Ratings

VIN Pin.....	-0.3V~23V
OUT Pin.....	-0.9V~23V
SS, CE, FB Pin.....	-0.3V~(VIN+0.3)V
Power dissipation.....	570mW
Operating Temperature Range.....	-30°C to 85°C
Operating Junction Temperature.....	125°C
Storage Temperature Range.....	-55°C to 125°C
Lead temperature (SOT-26, Soldering, 10sec).....	260°C
ESD Level (Human Body Model).....	2KV
ESD Level (Machine Model).....	200V

Continuous Power Dissipation derate 7.1mW/°C above 70°C

Caution:

Stresses beyond the ratings specified in "Absolute Maximum Ratings" may cause permanent damage to the device. This is a stress only rating and operation of the device at these or any other conditions above those indicated in the operational sections of this specification is not implied.

Electrical Characteristics

($T_A = +25^\circ\text{C}$ unless otherwise stated, $V_{IN}=15\text{V}$, $CE=V_{IN}$, $I_{LOAD}=5\mu\text{A}$)

PARAMETER	CONDITIONS	MIN	TYP	MAX	UNITS
INPUT POWER					
Input Voltage		4	-	21	V
Nominal Supply Current	$CE=V_{IN}$	-	30	60	μA
Shutdown Supply Current	$CE=GND$	-	1	5	μA
REFERENCE VOLTAGE					
Feedback Reference	$FB=OUT$ $V_{IN}=6\text{V to }18\text{V}$, $I_{LOAD}=1\text{mA}$		1.25		V
Reference Voltage Tolerance				2	%
Feedback Input Current	$V_{FB}=1.3\text{V}$		10		nA
OUTPUT					
Output Current Limit		60	90	-	mA
Output Reverse Leakage Current	$V_{IN}=\text{unconnected}$, OUT set to 5V	-	50	-	μA
Capacitive Load Requirement		0.23			$\mu\text{F}/\text{mA}$
Dropout Voltage	$I_{LOAD}=30\text{mA}$	-	0.25	0.35	V
Ripple Rejection	$F=120\text{Hz}$, $e_{in}=1\text{Vrms}$, $i_{out}=10\text{mA}$	-	60		dB
	$F=10\text{KHz}$, $e_{in}=1\text{Vrms}$, $i_{out}=10\text{mA}$	-	45		dB
Soft Start					
Soft Start Current		-	2	-	μA
CE					
CE Input Current	$CE=0$ or 15V	-1	-	1	μA
CE Input Level	Enable	1.4	-	-	V
	Disable	-	-	0.25	V
THERMAL PROTECTION					
Thermal Protection	V_{OUT} short to GND		125		$^\circ\text{C}$
Hysteresis			20		$^\circ\text{C}$

Typical Performance Characteristics

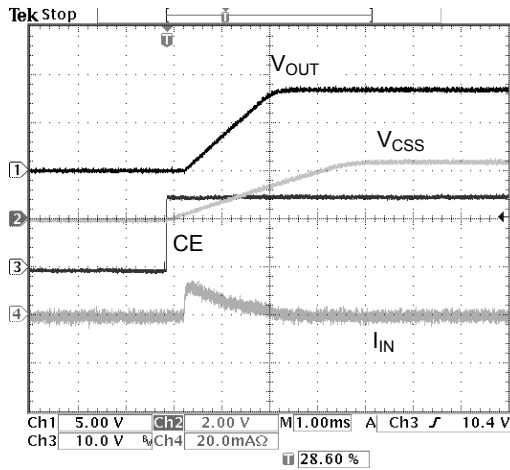

Fig. 4 Start up waveform $C_{SS}=3.3nF$

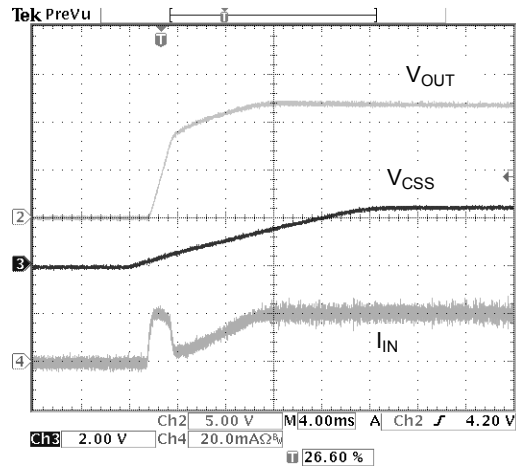

Fig. 5 WLED current waveform $C_{SS}=15nF$

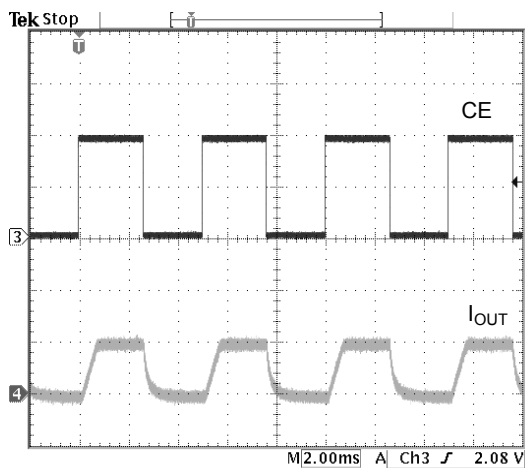

Fig. 6 WLED current waveform $C_{SS}=1nF$,
 $C_{OUT}=2.2\mu F$, $F=200Hz$

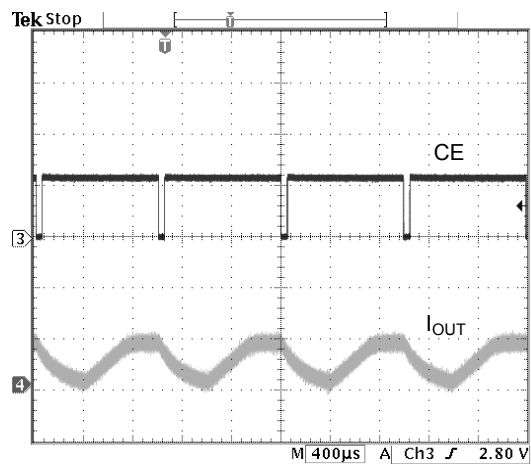

Fig. 7 WLED current waveform $C_{SS}=1nF$,
 $C_{OUT}=2.2\mu F$, $F=1KHZ$

Application Information

Capacitor Selection

The input capacitor is needed between the input and GND to stabilize V_{in} . The input capacitor should be at least 0.1 μ F to have a beneficial effect. Higher values will improve line transient response.

The LD6902 requires an output capacitor to stabilize the internal control loop. For stable operation, the output capacitor should use at least 1 μ F for loads smaller than 4.5mA, 0.23 μ F/mA for loads greater than 4.5mA and its ESR must be less than 1 ohm.

X5R or X7R type capacitors are recommended for input and output capacitors.

Current Limit

Output current is limited to 90mA (typical). When current limit engages, the output voltage scales back linearly until the overcurrent condition ends. Take care not to exceed the power dissipation ratings of the package.

Thermal Shutdown

When the junction temperature exceeds $T_j=125^{\circ}\text{C}$, the thermal sensor will turn off the pass transistor and allowing the IC to cool. The thermal sensor turns the pass transistor on after the IC's junction temperature cools by 20°C (typical).

Package Information

SOT-26

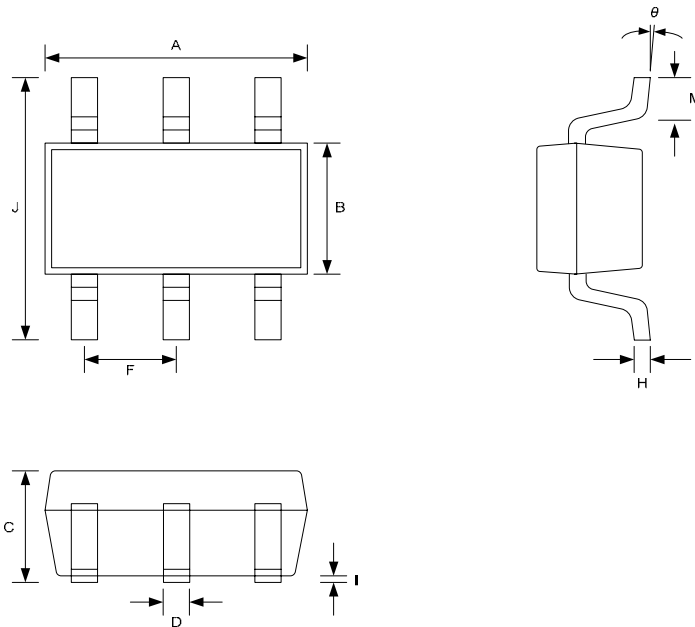

Symbol	Dimension in Millimeters		Dimensions in Inches	
	Min	Max	Min	Max
A	2.692	3.099	0.106	0.122
B	1.397	1.803	0.055	0.071
C	-----	1.450	-----	0.058
D	0.300	0.550	0.012	0.022
F	0.838	1.041	0.033	0.041
H	0.080	0.254	0.003	0.010
I	0.050	0.150	0.002	0.006
J	2.600	3.000	0.102	0.118
M	0.300	0.600	0.012	0.024
θ	0°	10°	0°	10°

Important Notice

Leadtrend Technology Corp. reserves the right to make changes or corrections to its products at any time without notice. Customers should verify the datasheets are current and complete before placing order.

Revision History

Rev.	Date	Change Notice
00	2/25/2005	Original Specification.
01		Application Circuit Revision.
02		Package Outline Correction
03	6/15/2006	Misspelling Correction