

PAN3101 LOW COST CMOS OPTICAL MOUSE SENSOR

General Description

The PAN3101 is a low cost CMOS process optical mouse sensor with DSP integration chip that serves as a non-mechanical motion estimation engine for implementing a computer mouse.

Features

- ❑ Single 5.0 volt power supply
- ❑ Precise optical motion estimation technology
- ❑ Complete 2-D motion sensor
- ❑ No mechanical parts
- ❑ Accurate motion estimation over a wide range of surfaces
- ❑ High speed motion detection up to 21 inches/sec
- ❑ High resolution up to 800dpi
- ❑ Register setting for low power dissipation
- ❑ Power saving mode during times of no movement
- ❑ Serial Interface for programming and data transfer
- ❑ I/O pin 5.0 volt tolerance

Key Specification

Power Supply	Wide operating supply range 4.25V~5.5V
Optical Lens	1:1
System Clock	18.432 MHz
Speed	21 inches/sec
Resolution	400/800dpi
Frame Rate	3000 frames/sec
Operating Current	10mA @Mouse moving (Normal) 5mA @Mouse not moving (Sleep) 100uA @Power down mode
Package	Staggered DIP8

Ordering Information

Order number	I/O	Resolution
PAN3101DB	CMOS output	800 cpi

1. Pin Description

Pin No.	Name	Type	Definition
1	OSCIN	IN	Resonator input
2	OSCOUT	OUT	Resonator output
3	SDIO	I/O	Serial interface bi-direction data
4	SCLK	IN	Serial interface clock
5	LED	OUT	LED control
6	VSS	GND	Chip ground
7	VDD	PWR	Chip power, 5V power supply
8	VREF	BYPASS	Voltage reference

Pin Assign

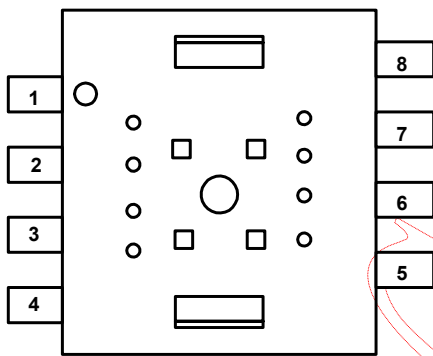

Figure 1. Top View Pinout

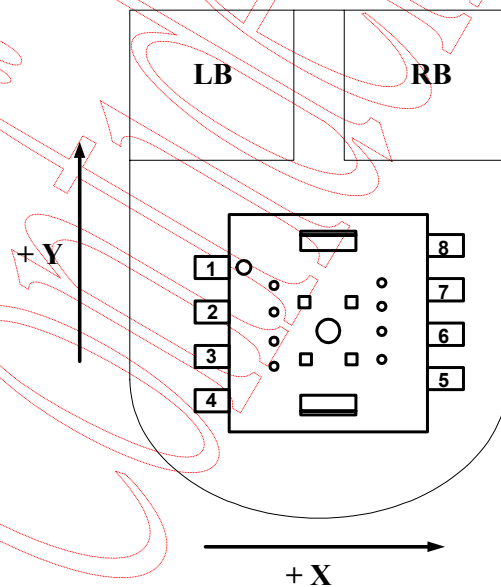

Figure 2. Top View of Mouse

2. Block Diagram and Operation

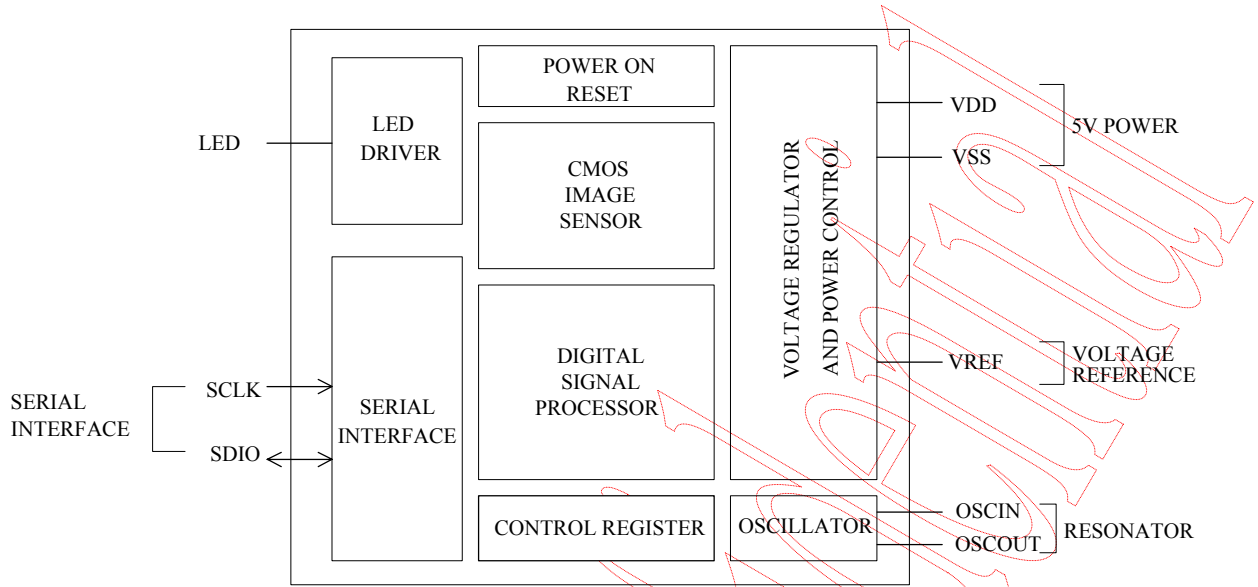

Figure 3. Block diagram

The PAN3101 is a low cost CMOS-process optical mouse sensor with DSP integration chip that serves as a non-mechanical motion estimation engine for implementing a computer mouse. It is based on new optical navigation technology, which measures changes in position by optically acquiring sequential surface images (frames) and mathematically determining the direction and magnitude of movement. The sensor is in a 8pin optical package. The current X and Y information are available in registers accessed via a serial port.

3. Registers and Operation

The PAN3101 can be programmed through registers, via the serial port, and DSP configuration and motion data can be read from these registers. All registers not listed are reserved, and should never be written by firmware.

3.1 Registers

Address	Name	R/W	Reset Value	Data Type
0x00	Operation_Mode1	R/W	0x00	Bit field
0x01	Product_ID1	R	0x01	Bit field
0x02	Delta_Y	R	-	Eight bits 2's complement number
0x03	Delta_X	R	-	Eight bits 2's complement number
0x04	Image_Quality	R	-	Eight bits unsigned integer
0x05 0x13	-	-	-	Reserve for future use
0x14	Product_ID2	R	0x10	Eight bits [11:4] number with the product identifier
0x15	Product_ID2	R	0x1N	Four-bits [3:0] number with the product identifier Reserved [3:0] number is reserved for future
0x16	Motion_Status	R	-	Bit field
0x17	Delta_X	R	-	Eight bits 2's complement number
0x18	Delta_Y	R	-	Eight bits 2's complement number
0x19	Image_Quality	R	-	Eight bits unsigned integer
0x1A	Operation_Mode2	R/W	-	Bit field
0x1B	Configuration	R/W	-	Bit field
0x1C 0x3F	-	-	-	Reserve for future use
0x40	Operation_Mode3	R/W	0x20	Bit field
0x41	Product_ID3	R	0x41	Bit field
0x42	Delta_Y	R	-	Eight bits 2's complement number
0x43	Delta_X	R	-	Eight bits 2's complement number
0x44	Image_Quality	R	-	Eight bits unsigned integer

3.2 Register Descriptions

0x00	Operation_Mode1								
Bit	7	6	5	4	3	2	1	0	
Field	Reset	PD_enh	Reserve [5:1]					Slp_enl	
Usage	Register 0x00 allows the user to change the operation of the sensor. Shown below are the bits, their default values, and optional values. If Slp_enl=0, After 1 sec not moving during normal mode, the chip will enter sleep mode, and keep on sleep mode until moving is detected or wakeup is asserted.								
Notes	Field Name	Description							
	Reset	Full chip reset 0 = Normal operation mode (Default) 1 = Full chip reset							
	PD_enh	Power down mode 0 = Normal operation mode (Default) 1 = Power down mode							
	Reserved [5:1]	Reserved for future							
Slp_enl	Sleep mode enable/disable 0 = Enable (Default) 1 = Disable								
0x01	Product_ID1								
Bit	7	6	5	4	3	2	1	0	
Field	PID [7:5]			Reserve [4:1]				Opstate	
Usage	Product ID of PAN3101 and operation state of the mouse.								
Notes	Field Name	Description							
	PID [7:5]	The product ID is 000							
	Reserved [4:1]	Reserved for future							
	Opstate	Operation state 0 = Sleep state 1 = Normal state							
0x02	Delta_Y								
Bit	7	6	5	4	3	2	1	0	
Field	Y7	Y6	Y5	Y4	Y3	Y2	Y1	Y0	
Usage	Y movement is counts since last report. Absolute value is determined by resolution. Reading clears the register. Report range -128~+127.								

0x03	Delta_X							
Bit	7	6	5	4	3	2	1	0
Field	X7	X6	X5	X4	X3	X2	X1	X0
Usage	X movement is counts since last report. Absolute value is determined by resolution. Reading clears the register. Report range -128~+127.							
0x04	Image_Quality							
Bit	7	6	5	4	3	2	1	0
Field	Imgqa[7:0]							
Usage	Image Quality is a quality level of the sensor in the current frame. Report range 0~255.							
Notes	Field Name	Description						
	Imgqa[7:0]	Image quality report range: 0(worst) ~ 255(best).						
0x14	Product_ID2							
Bit	7	6	5	4	3	2	1	0
Field	PID[11:4]							
Usage	The value in this register can't change. It can be used to verify that the serial communications link is OK.							
0x15	Product_ID2							
Bit	7	6	5	4	3	2	1	0
Field	PID[3:0]				Reserved [3:0]			
Usage	The value in this register can't change. PID[3:0] can be used to verify that the serial communications link is OK. Reserved [3:0] is a value between 0x0 and 0xF, it can't be used to verify that the serial communications.							

0x16		Motion_Status						
Bit	7	6	5	4	3	2	1	0
Field	Motion	Reserved[6:5]		DYOVF	DXOVF	Reserved[2:1]		RES
Usage	<p>Register 0x16 allows the user to determine if motion has occurred since the last time it was read. If so, then the user should read registers 0x17 and 0x18 to get the accumulated motion. It also tells if the motion buffers have overflowed since the last reading. The current resolution is also shown.</p> <p>Reading this register freezes the Delta_X and Delta_Y register values. Read this register before reading the Delta_X and Delta_Y registers. If Delta_X and Delta_Y are not read before the motion register is read a second time, the data in Delta_X and Delta_Y will be lost.</p>							
Notes	Field Name	Description						
	Motion	Motion since last report or PD 0 = No motion (Default) 1 = Motion occurred, data ready for reading in Delta_X and Delta_Y registers						
	Reserved[6:5]	Reserved for future						
	DYOVF	Motion Delta Y overflow, ΔY buffer has overflowed since last report 0 = No overflow (Default) 1 = Overflow has occurred						
	DXOVF	Motion Delta X overflow, ΔX buffer has overflowed since last report 0 = No overflow (Default) 1 = Overflow has occurred						
	Reserved [2:1]	Reserved for future						
	RES	Resolution in counts per inch 0 = 800 (Default) 1 = 400						
0x17		Delta_X						
Bit	7	6	5	4	3	2	1	0
Field	X7	X6	X5	X4	X3	X2	X1	X0
Usage	X movement is counts since last report. Absolute value is determined by resolution. Reading clears the register. Report range -128~+127.							
0x18		Delta_Y						
Bit	7	6	5	4	3	2	1	0
Field	Y7	Y6	Y5	Y4	Y3	Y2	Y1	Y0
Usage	Y movement is counts since last report. Absolute value is determined by resolution. Reading clears the register. Report range -128~+127.							

0x19	Image_Quality							
Bit	7	6	5	4	3	2	1	0
Field	Imgqa[7:0]							
Usage	Image Quality is a quality level of the sensor in the current frame. Report range 0~255.							
Notes	Field Name	Description						
	Imgqa[7:0]	Image quality report range: 0(worst) ~ 255(best).						
0x1A	Operation_Mode2							
Bit	7	6	5	4	3	2	1	0
Field	Reset	PD_enh	Reserved[5:4]		LEDsht_enh	Slp_enh	Slpmu_enh	Wakeup
Usage	<p>Register 0x1A allows the user to change the operation of the sensor. Shown below are the bits, their default values, and optional values.</p> <p>Operation_Mode2[2:0] “0xx”=Disable sleep mode “110”=Force enter sleep “101”=Force wakeup from sleep mode</p> <p>Notes:</p> <ol style="list-style-type: none"> After 1 sec not moving during normal mode, chip will enter sleep mode, and keep on sleep mode until moving is detected or wakeup is asserted. Only one of these two bits Slpmu_enh and Wakeup can be set to 1 at the same time, others have to be set to 0. After a period of time, the bits, which was set to 1, will be reset to 0 by internal signal. 							
Notes	Field Name	Description						
	Reset	Full chip reset 0 = Normal operation mode (Default) 1 = Full chip reset						
	PD_enh	Power down mode 0 = Normal operation mode (Default) 1 = Power down mode						
	Reserved[5:4]	Reserved for future						
	Ledsht_enh	LED shutter enable / disable 0 = Disable 1 = Enable (Default)						
	Slp_enh	Sleep mode enable/disable 0 = Disable 1 = Enable (Default)						
	Slpmu_enh	Manual enter sleep mode, set “1” will enter sleep and this bit will be reset to “0”						
	Wakeup	Manual wake up from sleep mode, set “1” will enter wakeup and this bit will be reset to “0”						

0x1B	Configuration							
Bit	7	6	5	4	3	2	1	0
Field	RES	Reserved[6:0]						
Usage	The Configuration register allows the user to change the configuration of the sensor. Shown below are the bits, their default values, and optional values.							
Notes	Field Name	Description						
	RES	Output resolution setting 0 = 800 (Default) 1 = 400						
	Reserved[6:0]	Reserved for future						
0x40	Operation_Mode3							
Bit	7	6	5	4	3	2	1	0
Field	Reset	PD_enh	Ledsht_enh	Reserve [4:1]				Slp_enl
Usage	Register 0x40 allows the user to change the operation of the sensor. Shown below are the bits, their default values, and optional values. If Slp_enl=0, After 1 sec not moving during normal mode, the chip will enter sleep mode, and keep on sleep mode until moving is detected or wakeup is asserted.							
Notes	Field Name	Description						
	Reset	Full chip reset 0 = Normal operation mode (Default) 1 = Full chip reset						
	PD_enh	Power down mode 0 = Normal operation mode (Default) 1 = Power down mode						
	Ledsht_enh	LED shutter enable / disable 0 = Disable 1 = Enable (Default)						
	Reserved [4:1]	Reserved for future						
	Slp_enl	Sleep mode enable/disable 0 = Enable (Default) 1 = Disable						

0x41	Product_ID3							
Bit	7	6	5	4	3	2	1	0
Field	PID [7:5]			Reserve [4:1]				Opstate
Usage	Product ID of PAN3101 and operation state of the mouse.							
Notes	Field Name	Description						
	PID [7:5]	The product ID is 010						
	Reserved [4:1]	Reserved for future						
	Opstate	Operation state 0 = Sleep state 1 = Normal state						
0x42	Delta_Y							
Bit	7	6	5	4	3	2	1	0
Field	Y7	Y6	Y5	Y4	Y3	Y2	Y1	Y0
Usage	Y movement is counts since last report. Absolute value is determined by resolution. Reading clears the register. Report range -128~+127.							
0x43	Delta_X							
Bit	7	6	5	4	3	2	1	0
Field	X7	X6	X5	X4	X3	X2	X1	X0
Usage	X movement is counts since last report. Absolute value is determined by resolution. Reading clears the register. Report range -128~+127.							
0x44	Image_Quality							
Bit	7	6	5	4	3	2	1	0
Field	Imgqa[7:0]							
Usage	Image Quality is a quality level of the sensor in the current frame. Report range 0~255.							
Notes	Field Name	Description						
	Imgqa[7:0]	Image quality report range: 0(worst) ~ 255(best).						

4. Specifications

Absolute Maximum Ratings

Symbol	Parameter	Min	Max	Unit	Notes
T _{STG}	Storage temperature	-40	85	°C	
TA	Operating Temperature	-15	55	°C	
	Lead Solder Temp		260	°C	For 10 seconds, 1.6mm below seating plane.
V _{DD}	DC supply voltage	-0.5	5.5	V	
ESD			2	kV	All pins, human body model MIL 883 Method 3015
V _{IN}	DC input voltage	-0.5	5.5	V	SDIO, SCLK, VDD

Recommend Operating Condition

Symbol	Parameter	Min.	Typ.	Max.	Unit	Notes
T _A	Operating Temperature	0		40	°C	
V _{DD}	Power supply voltage	4.25	5.0	5.5	V	
V _N	Supply noise			100	mV	Peak to peak within 0-100 MHz
F _{CLK}	Clock Frequency		18.432	24.576	MHz	Set by ceramic resonator
FR	Frame Rate		3000	4000	Frames/s	4000Frames/s @ F _{CLK} =24.567MHz
SCLK	Serial Port Clock Frequency			10	MHz	
Z	Distance from lens reference plane to surface	2.3	2.4	2.5	mm	Refer to Figure 5.
S	Speed	0	21	28	Inches/sec	28inches/sec @ F _{CLK} =24.567MHz
A	Acceleration	0.1		20	g	
R	Resolution			800	cpi	

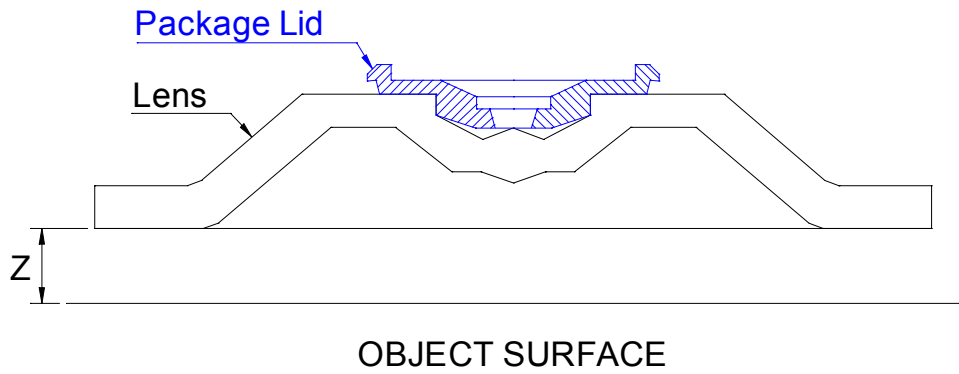

Figure 4. Distance from Lens Reference Plane to Surface

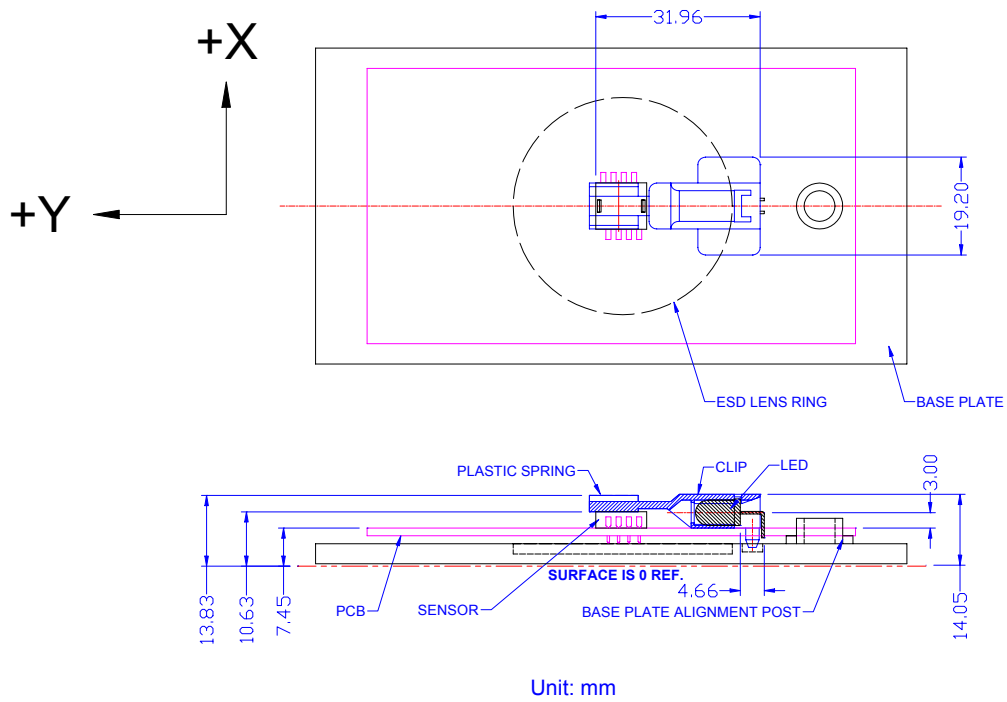

Figure 5. PCB assembly

AC Operating Condition

Electrical Characteristics over recommended operating conditions. Typical values at 25 °C, $V_{DD}=5.0$ V, $F_{CLK}=18.432$ MHz

Symbol	Parameter	Min.	Typ.	Max.	Unit	Notes
t_{HOLD}	SDIO read hold time		3		us	Minimum hold time for valid data. (Refer to Figure 8)
t_{RESYNC}	Serial Interface RESYNC.	1			us	@3000frame/sec (Refer to Figure 9)
t_{SIWTT}	Serial Interface Watchdog Timer Timeout	1.7			ms	@3000frame/sec (Refer to Figure 9)
t_{PDR}	PD Pulse Register			333	us	One frame time maximum after setting bit 6 in the Operation_Mode register @3000frame/sec. (Refer to Figure 10)
t_{PUPD}	Power Up from deactivate the Power Down mode	3		30.5	ms	From deactivate power down mode to valid quad signals. After t_{PUPD} , all registers contain valid data from first image after deactivate power down mode. Note that an additional 90 frames for Auto-Exposure (AE) stabilization may be required if mouse movement occurred while PD was high.
t_{PU}	Power Up from $V_{DD}\uparrow$	3		30.5	ms	From $V_{DD}\uparrow$ to valid quad signals. 500usec + 90frames.
t_r, t_f	Rise and Fall Times: SDIO		25, 20		ns	$C_L = 30$ pf
t_r, t_f	Rise and Fall Times: ILED		10, 10		ns	LED bin grade: R; $R1=100$ ohm



DC Electrical Characteristics

Electrical Characteristics over recommended operating conditions. Typical values at 25 °C, V_{DD} =5.0 V, F_{CLK}=18.432MHz

Symbol	Parameter	Min.	Typ.	Max.	Unit	
Type: PWR						
I _{DD}	Supply Current Mouse moving (Normal)		10		mA	SCLK, SDIO = no load
I _{DD}	Supply Current Mouse not moving (sleep1)		5		mA	
I _{DDPD}	Supply Current (Power Down)		100		uA	SCLK, SDIO = high
Type: SCLK, SDIO						
V _{IH}	Input voltage HIGH	2.0				
V _{IL}	Input voltage LOW			0.7	V	
V _{OH}	Output voltage HIGH	2.4			V	@I _{OH} = 2mA (SDIO only)
V _{OL}	Output voltage LOW			0.6	V	@I _{OL} = 2mA (SDIO only)
Type: OSCIN						
V _{IH}	Input voltage HIGH	2.0			V	When driving from an external source
V _{IL}	Input voltage LOW			0.7	V	When driving from an external source
Type: LED						
V _{OL}	Output voltage LOW			150	mV	@I _{OL} = 25mA

5. Serial Interface

The synchronous serial port is used to set and read parameters in the PAN3101, and can be used to read out the motion information instead of the quadrature data pins.

SCLK: The serial clock line. It is always generated by the host micro-controller.

SDIO: The serial data line used for write and read data.

5.1 Transmission Protocol

The transmission protocol is a two-wire link, half duplex protocol between the micro-controller and PAN3101. All data changes on SDIO are initiated by the falling edge on SCLK. The host micro-controller always initiates communication; the PAN3101 never initiates data transfers.

The transmission protocol consists of the two operation modes:

- Write Operation.
- Read Operation.

Both of the two operation modes consist of two bytes. The first byte contains the address (seven bits) and has a bit7 as its MSB to indicate data direction. The second byte contains the data.

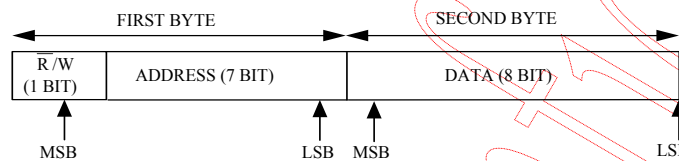

Figure 6. Transmission protocol

5.1.1 Write Operation

A write operation, which means that data is going from the micro-controller to the PAN3101, is always initiated by the micro-controller and consists of two bytes. The first byte contains the address (seven bits) and has a “1” as its MSB to indicate data direction. The second byte contains the data. The transfer is synchronized by SCLK. The micro-controller changes SDIO on falling edges of SCLK. The PAN3101 reads SDIO on rising edges of SCLK.

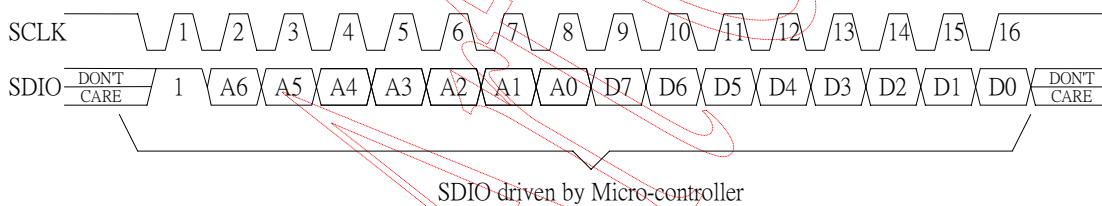

Figure 7. Write operation

5.1.2 Read Operation

A read operation, which means that data is going from the PAN3101 to the micro-controller, is always initiated by the micro-controller and consists of two bytes. The first byte contains the address, is written by the micro-controller, and has a “0” as its MSB to indicate data direction. The second byte contains the data and is driven by the PAN3101. The transfer is synchronized by SCLK. SDIO is changed on falling edges of SCLK and read on every rising edge of SCLK. The micro-controller must go to a high Z state after the last address data bit. The PAN3101 will go to the high Z state after the last data bit.

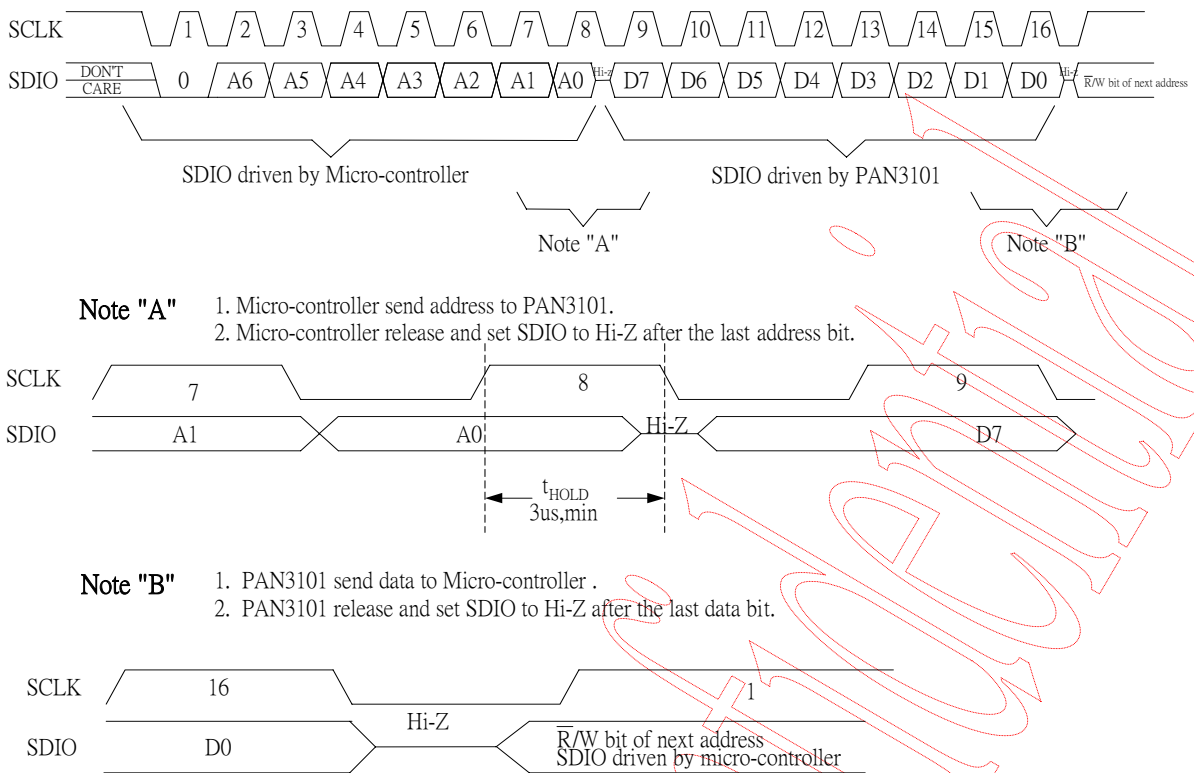

Figure 8. Read operation

5.2 Re-Synchronous Serial Interface

5.2.1 Power On Problem

The problem occurs if the PAN3101 powers up before the microprocessor sets the SCLK and SDIO lines to be output.

5.2.2 ESD Events

The PAN3101 and the micro-controller might get out of synchronization due to ESD events.

If the PAN3101 and the micro-controller might get out of synchronization due to power on problem or ESD events. An easy way to solve this is to waiting for watchdog timer timeout

5.3 Collision Detection on SDIO

The only time that the PAN3101 drives the SDIO line is during a READ operation. To avoid data collisions, the micro-controller should release SDIO before the falling edge of SCLK after the last address bit. The PAN3101 begins to drive SDIO after the next falling edge of SCLK. The PAN3101 release SDIO of the rising SCLK edge after the last data bit. The micro-controller can begin driving SDIO any time after that. In order to maintain low power consumption in normal operation, the micro-controller should not leave SDIO floating until the next transmission (although that will not cause any communication difficulties).

5.4 Serial Interface Watchdog Timer Timeout

When there are only two pins to read register from PAN3101, and PD pin can't be used to re-synchronous function. If the microprocessor and the PAN3101 get out of sync, then the data either written or read from the registers will be incorrect. In such a case, an easy way to solve this condition is to toggle the SCLK

line from high to low to high and wait at least t_{SIWTT} to re-sync the parts after an incorrect read. The PAN3101 will reset the serial port but will not reset the registers and be prepared for the beginning of a new transmission.

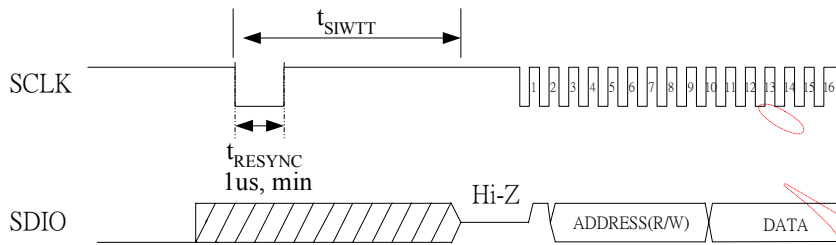

Figure 9. Re-synchronous serial interface using watchdog timer timeout

5.5 Power Down Mode

PAN3101 can be placed in a power-down mode by setting bit 6 in the Operation Mode register via a serial port write operation. After setting the configuration register, wait at least 1 frame times. To get the chip out of the power-down mode, clear bit 6 in the configuration register via a serial port write operation. In power-down mode, the serial interface watchdog timer is not available. But, The serial interface still can read/write normally. For an accurate report after leave power down mode, wait about 3ms before the micro-controller is able to issue any write/read operation to the PAN3101.

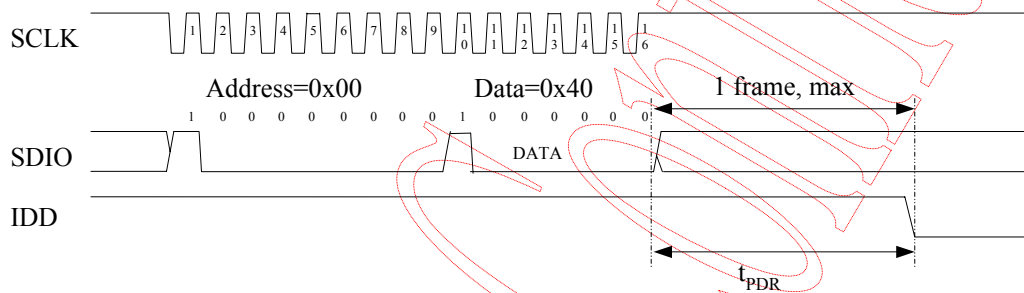

Figure 10. Power-down configuration register writing operation

5.6 Error Detection

1. The micro-controller can verify success of write operations by issuing a read command to the same address and comparing written data to read data.
2. The micro-controller can verify the synchronization of the serial port by periodically reading the product ID register.

6. Referencing Application Circuit

6.1 Recommended Typical Application using External LED Control

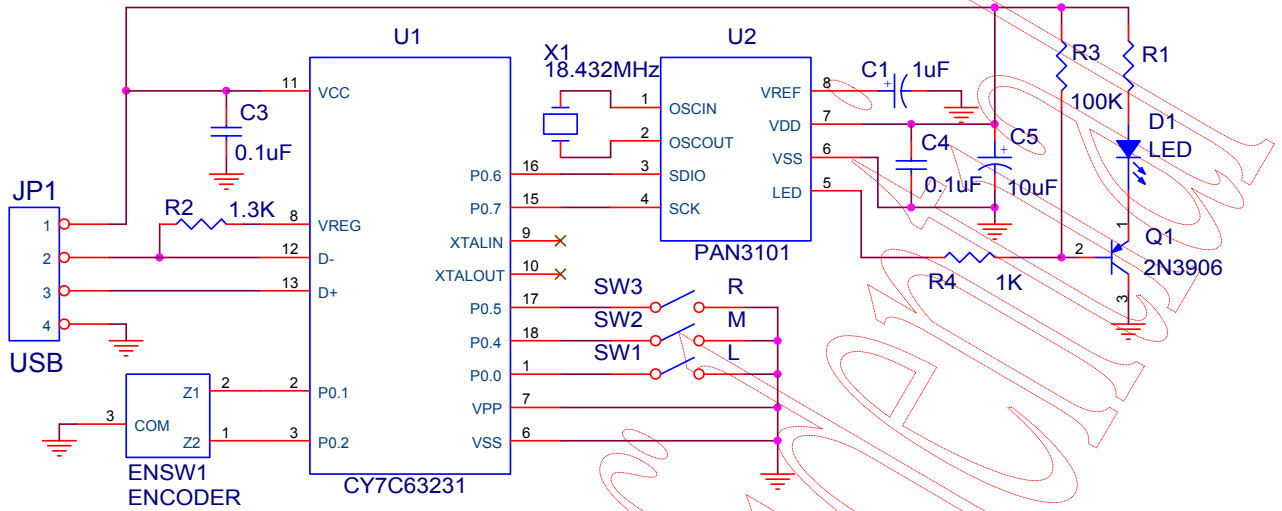

Figure 11. Application circuit using external LED

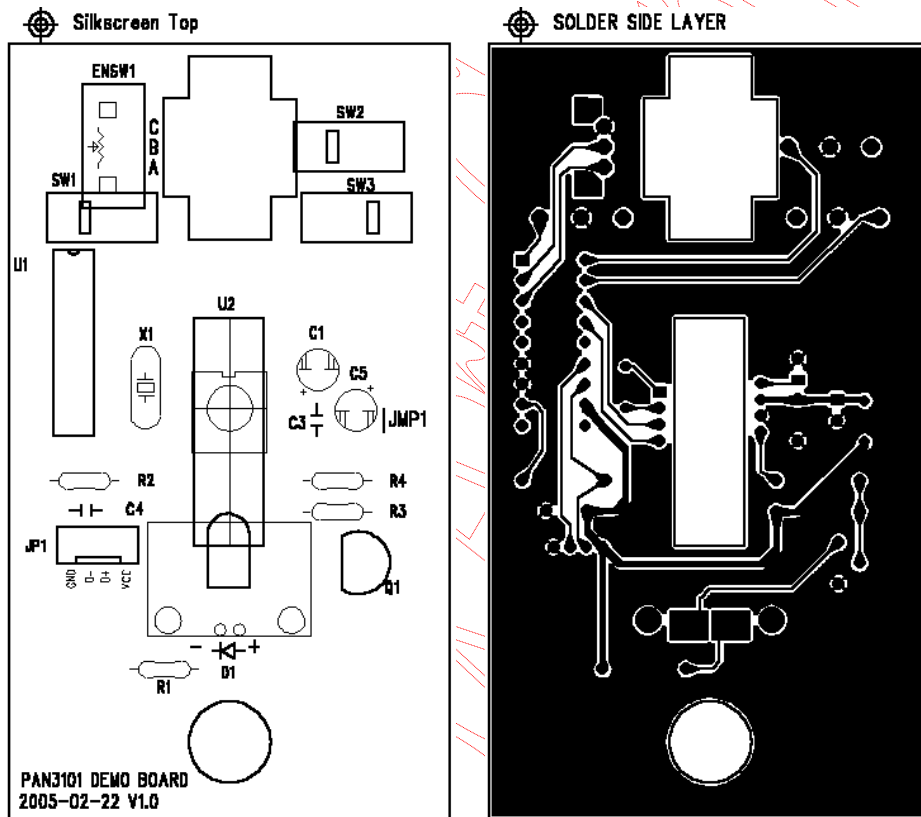

Figure 12. Example printed circuit board layout

6.2 Recommended Typical Application using Internal LED Control

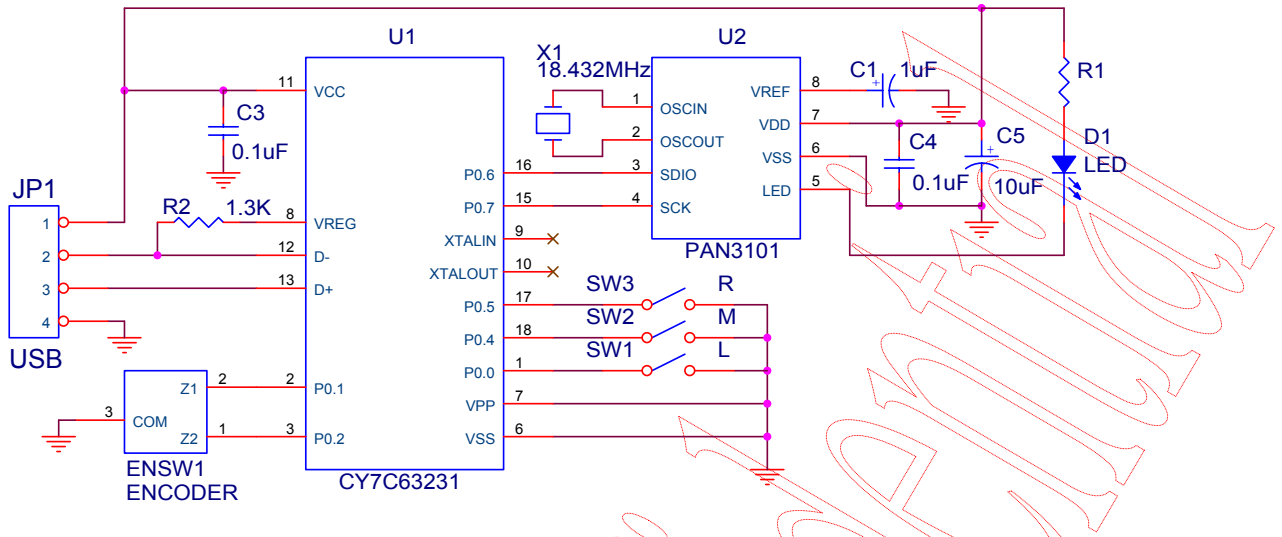

Figure 13. Application circuit using internal LED

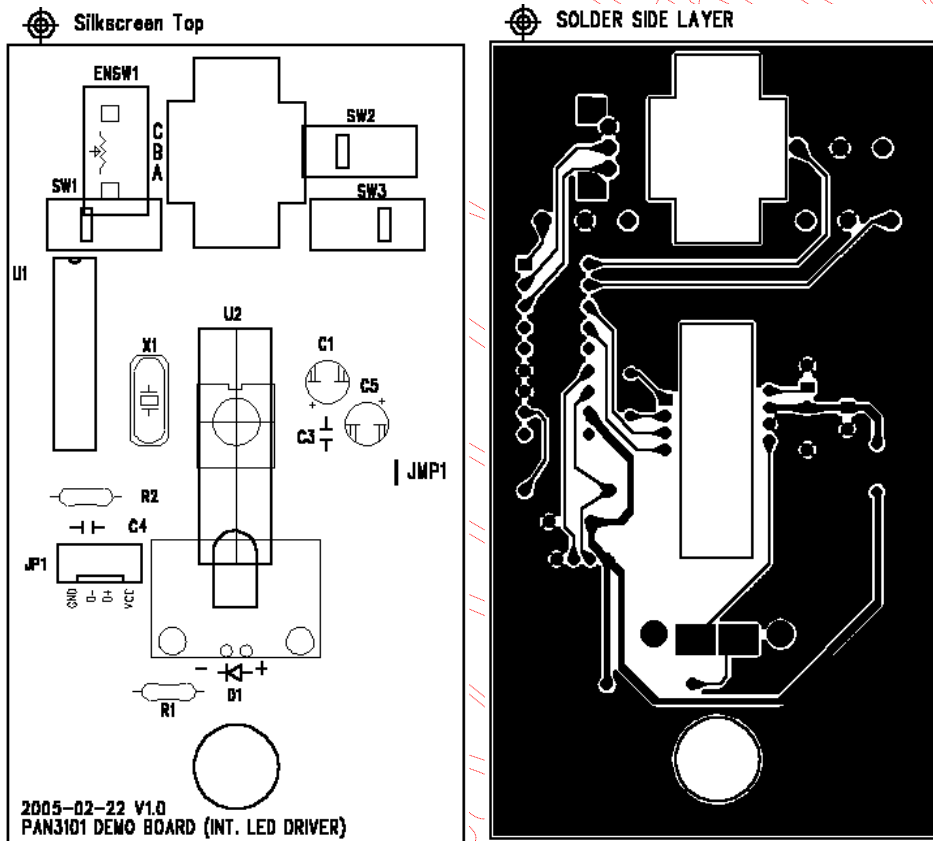

Figure 14. Example printed circuit board layout

6.3 PCB Layout Consideration

1. Caps for pins 7, 8 must have trace lengths less than **5mm**.
2. The trace lengths of OSCOUT, OSCIN must less than **6mm**.

6.4 Recommended Value for R1

Radiometric intensity of LED
Bin limits (mW/Sr at 20mA)

LED Bin grade	Min.	Typ.	Max.
N	14.7		17.7
P	17.7		21.2
Q	21.2		25.4

Note: Tolerance for each bin will be $\pm 15\%$

R1 value (ohm) for external LED control, VDD=5.0V

LED bin grade	Min.	Typ.	Max.
N	27	47	
P	27	47	
Q	27	47	

R1 value (ohm) for internal LED control, VDD=5.0V

LED bin grade	Min.	Typ.	Max.
N	47	100	
P	47	100	
Q	47	100	

7. Package Information

7.1 Package Outline Drawing

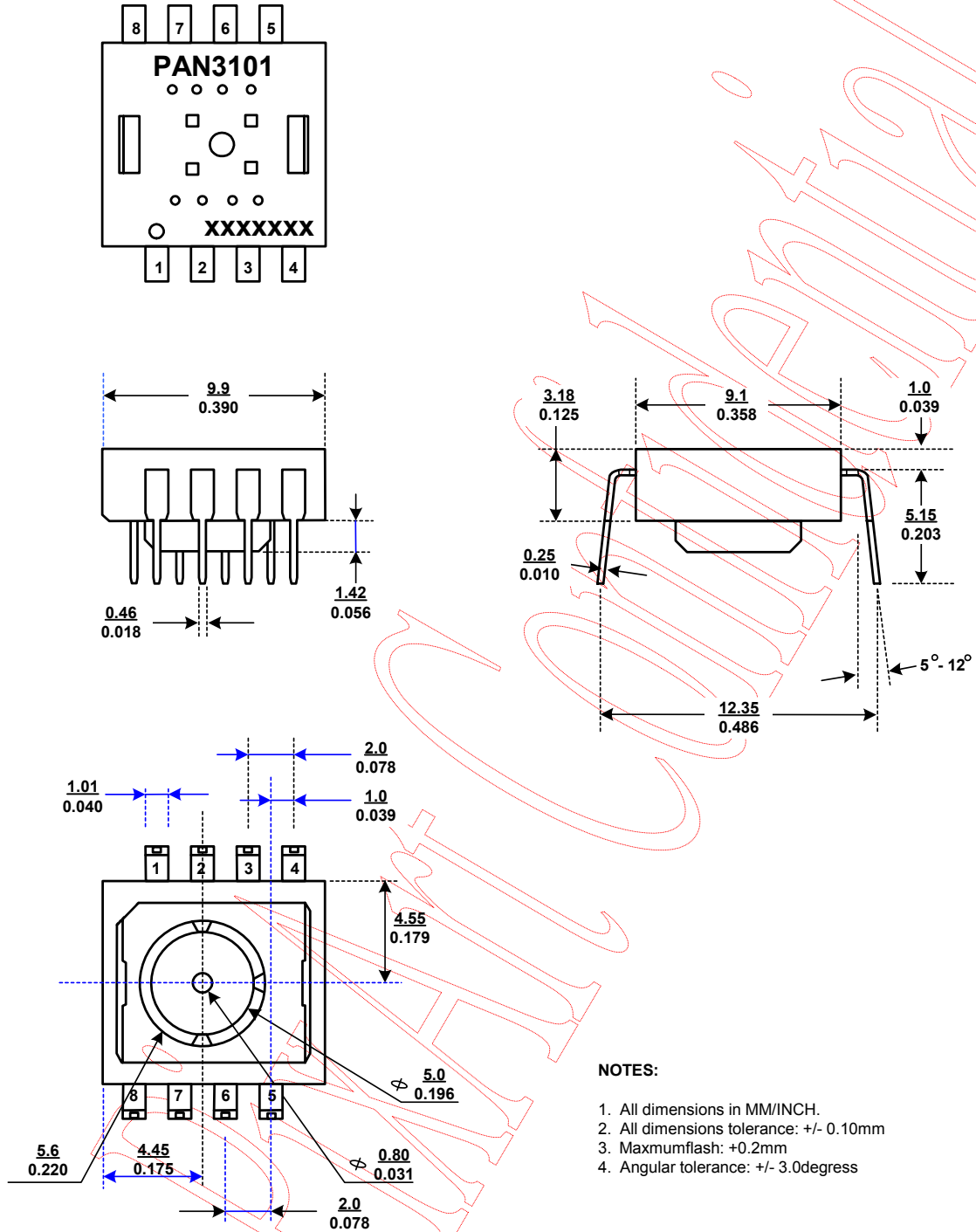

Figure 15. Package outline drawing

7.2 Recommended PCB Mechanical Cutouts and Spacing

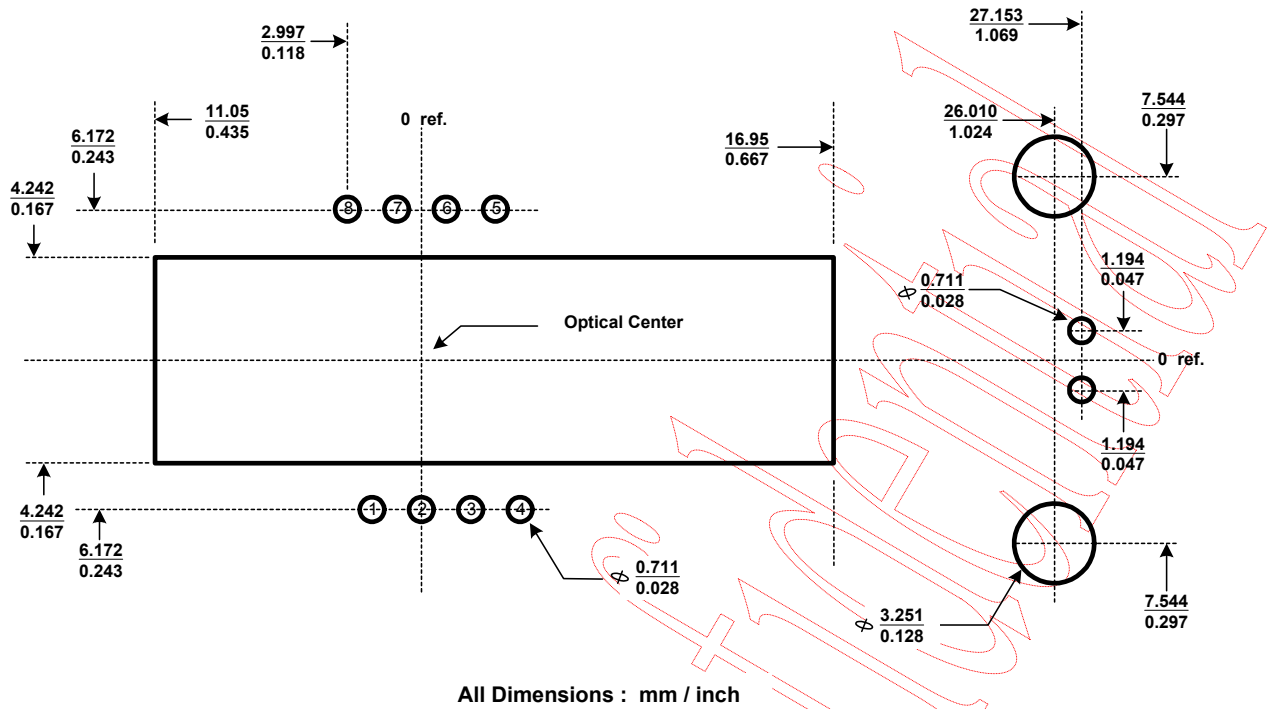

Figure 16. Recommended PCB mechanical cutouts and spacing

8. Update History

Version	Update	Date
V0.1	Creation, Preliminary 1 st version	03/01/2005
V0.2	3.1 Registers	03/02/2005
V1.0	6.4 Recommended Value for R1	03/31/2005