

One-dimensional PSD Plastic package

1-D PSD with plastic package

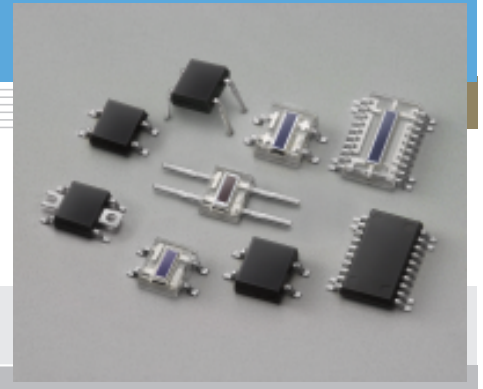

Hamamatsu offers a variety of 1-D PSDs (Position Sensitive Detectors) molded into plastic packages. These PSDs feature excellent position detection resolution, high resistance to disturbance background light and high reliability.

Features

- Excellent position detection resolution
- High reliability
- Thin, miniature plastic package
- Clear package passing wide wavelength range or visible-cut package reducing background light noise
- Surface mount package is available
- Suitable for high-speed, microscopic spot light: S7879, S8361
- High sensitivity in the red region: S8361
- High interelectrode resistance: S3271 to S3274-05, S7105-05, S5629-02

Applications

- Camera auto focus
- Range finder
- Optical proximity switch
- Displacement meter

■ General ratings / Absolute maximum ratings

Type No.	Dimensional outline	Active area (mm)	Resistance length (mm)	Absolute maximum ratings		
				Reverse voltage VR Max. (V)	Operating temperature Topr (°C)	Storage temperature Tstg (°C)
S6407	①	1 × 1	1	20	-25 to +85	-40 to +100
S6515		1 × 1.2				
S4580-04	②	0.8 × 1.5	1.5			
S4580-06						
S4581-04	②	1 × 2	2			
S4581-06						
S3271-05	③	1 × 2.5	2.5			
S4582-04	②					
S4582-06	③	1 × 3	3			
S3272-05	③					
S4583-04	②	1 × 3	3			
S4583-06						
S3273-05	③	1 × 3	3			
S7879	④					
S8361	②	1 × 3.5	3.5			
S4584-04						
S4584-06	③	1 × 4.2	4.2			
S3274-05	③					
S7105-04	⑤	1 × 4.2	4.2			
S7105-06						
S7105-05						
S5629	⑥	1 × 6	6			
S5629-01						
S5629-02						

NEW
NEW

■ Electrical and optical characteristics (Typ. Ta=25 °C, unless otherwise noted)

Type No.	Spectral response range λ (nm)	Peak sensitivity wavelength λ_p (nm)	Photo sensitivity S		Interelectrode resistance Rie Vb=0.1 V			Position detection error *1 VR=1 V spot light size = ϕ 300 μ m		Saturation photocurrent *2 Ist VR=1 V RL=1 k Ω	Dark current Id VR=1 V		Temp. coefficient of Id TCID (Times/°C)	Rise time tr *3 VR=1 V RL=1 k Ω		Terminal capacitance Ct VR=1 V f=10 kHz (pF)					
			$\lambda=650$ nm (A/W)	$\lambda=890$ nm (A/W)	Min. (k Ω)	Typ. (k Ω)	Max. (k Ω)	Typ. (μ m)	Max. (μ m)	(μ A)	Typ. (nA)	Max. (nA)		$\lambda=650$ nm (μ s)	$\lambda=890$ nm (μ s)						
S6407	760 to 1100	960	-	0.51	160	200	240	\pm 5	\pm 15	25	0.05	1	1.15	-	10	15					
S6515					100	140	180			30											
S4580-04	760 to 1100	960	-	0.51	100	140	180	\pm 10	\pm 20	30	0.05	1	1.15	-	10	15					
S4580-06	320 to 1100		0.35											3							
S4581-04	760 to 1060	920	-	0.51	100	140	180	\pm 10	\pm 20	30	0.05	1	1.15	-	10	15					
S4581-06	320 to 1060		0.38											3							
S3271-05	760 to 1060		-											0.51			320	400	480	-	15
S4582-04	760 to 1100	960	-	0.51	100	140	180	\pm 10	\pm 25	30	0.05	1	1.15	-	10	15					
S4582-06	320 to 1100		0.33											3							
S3272-05	760 to 1100		-											0.51			320	400	480	-	15
S4583-04	760 to 1100	960	-	0.51	100	140	180	\pm 10	\pm 30	30	0.05	1	1.15	-	10	15					
S4583-06	320 to 1100		0.33											3							
S3273-05	760 to 1100		-											0.51			320	400	480	-	15
S7879	440 to 1100		0.36											1			4				
S8361	400 to 1100	680	0.45	0.45	70	110	150	\pm 15	\pm 60	40				1	4	30					
S4584-04	760 to 1100	960	-	0.51	100	140	180	\pm 15	\pm 35	30	0.05	1	1.15	-	10	15					
S4584-06	320 to 1100		0.33											3							
S3274-05	760 to 1100		-											0.51			320	400	480	-	15
S7105-04	760 to 1100	960	-	0.51	100	140	180	\pm 15	\pm 40	30	0.1	2	1.15	-	5	40					
S7105-06	320 to 1100		0.38											2							
S7105-05	760 to 1100		-											0.51			320	400	480	-	15
S5629	760 to 1100	960	-	0.51	30	50	80	\pm 20	\pm 60	80	0.1	2	1.15	-	5	60					
S5629-01	320 to 1100		0.38											2							
S5629-02	760 to 1100		-											0.51			240	300	360	-	20

*1: In the range 75 % from the center of the active area to the edge.

*2: This indicates the upper limit of the photocurrent linearity over the entire incident light quantity and is defined as the photocurrent at a point where the linearity deviates by 10 %.

*3: Time required for output change from 10 to 90 % of the steady output value when stepped function light is input to the PSD.

■ Spectral response

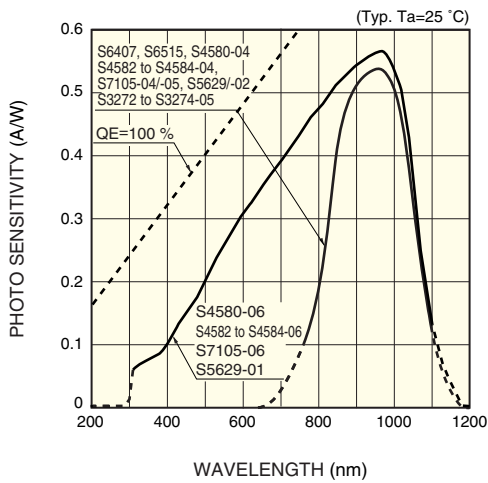

KPSDB0079EB

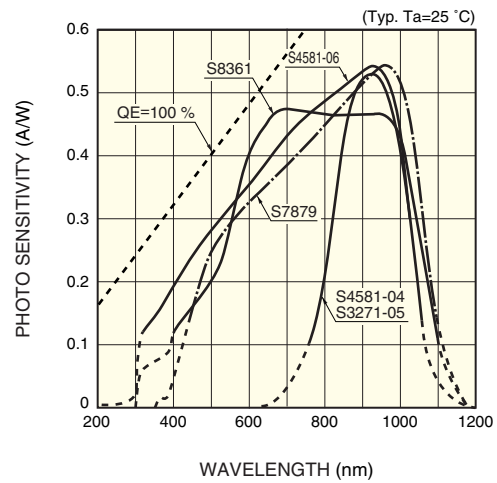

KPSDB0080EB

Photo sensitivity temperature characteristic (S4581-06)

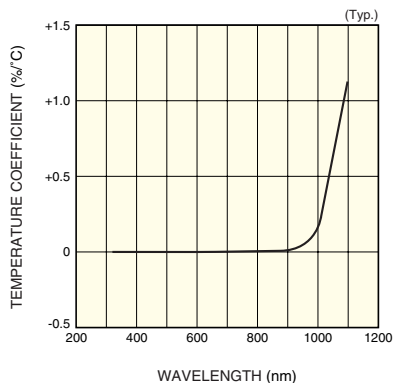

KPSDB0002EE

Dark current vs. reverse voltage

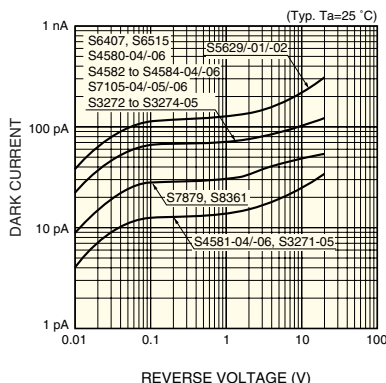

KPSDB0004EE

Saturation photocurrent vs. interelectrode resistance

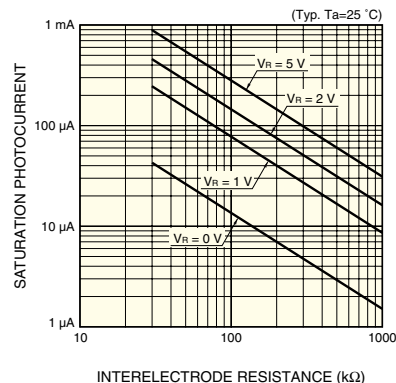

KPSDB0003EA

Rise time vs. reverse voltage

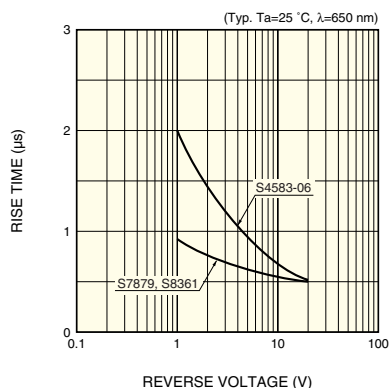

KPSDB00095EA

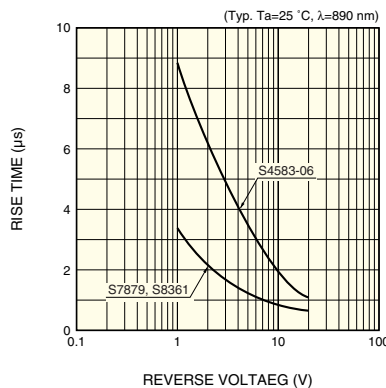

KPSDB00096EB

Position detection characteristic example (S4583-04, active area size: 1 × 3 mm)

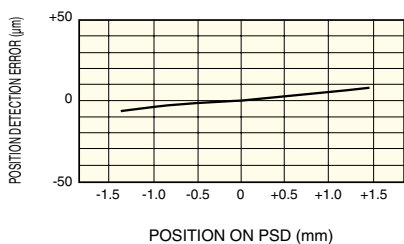
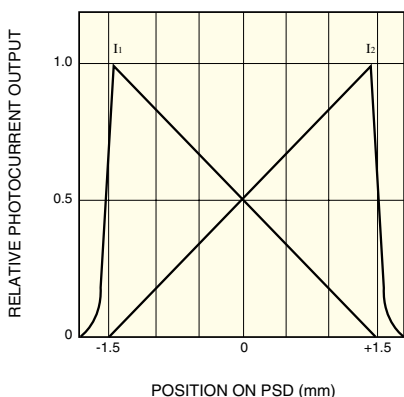

KPSDB00005EB

Definition of position detection error

When the electrical center of a PSD is assumed to be the position of incident light where light current I_1 equals I_2 , position detection error at each incident position can be defined by the following equation.

$$\text{Position detection error } (\mu\text{m}) = \text{Incident position} - \frac{I_2 - I_1}{I_1 + I_2} \times \frac{L}{2}$$

The electrical center is viewed as 0, I_1 as (+), and I_2 as (-).

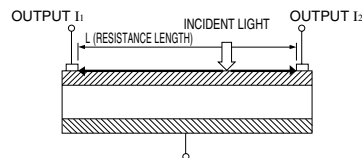

KPSDC0001EA

■ Dimensional outlines [unit: mm, tolerance unless otherwise noted: ± 0.1 , chip position accuracy (without ①) with respect to the package dimensions marked * X, $Y \leq \pm 0.2$, $\theta \leq \pm 2^\circ$]

① S6407, S6515 (Surface mounting type)

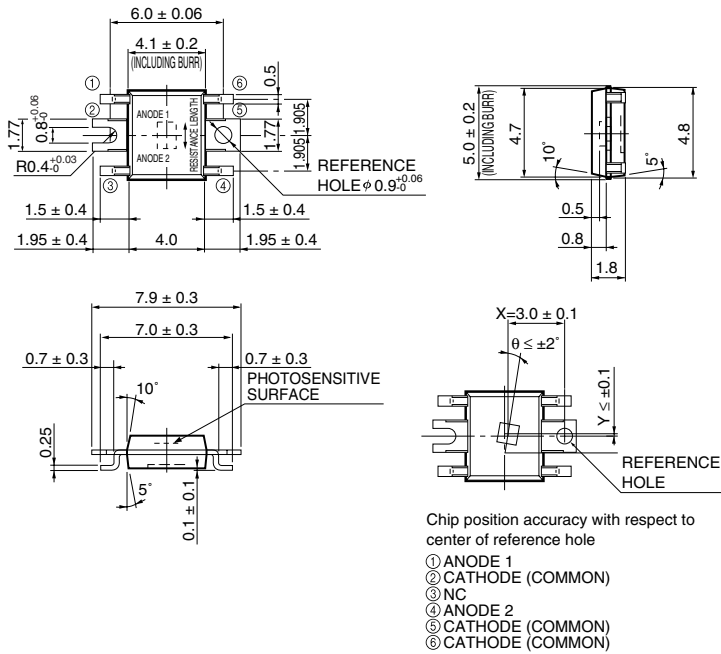

KPSDA0057EA

② S4580 to S4584-04/-06 (Surface mounting type)

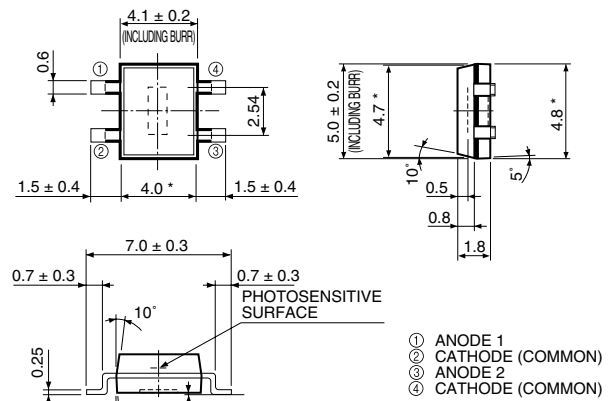

KPSDA0022EA

③ S3271 to S3274-05

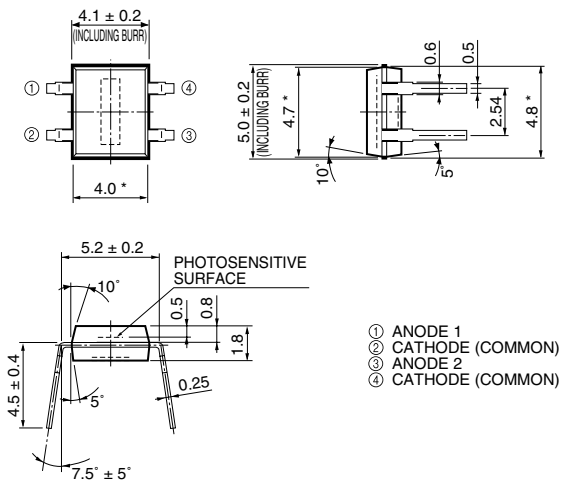

KPSDA0063EA

④ S7879, S8361

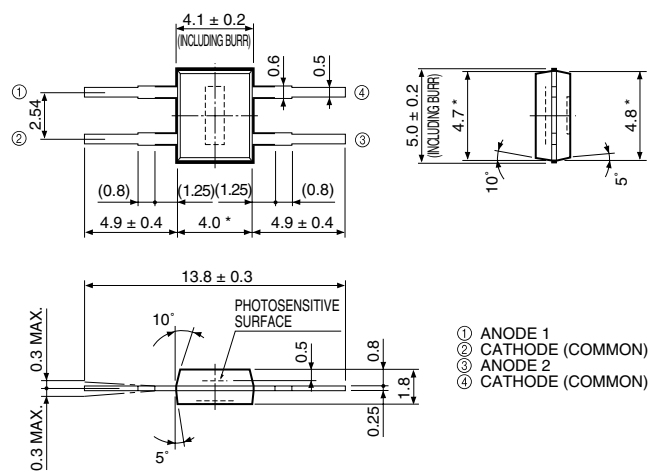

KPSDA0052EA

⑤ S7105-04/-05/-06 (Surface mounting type)

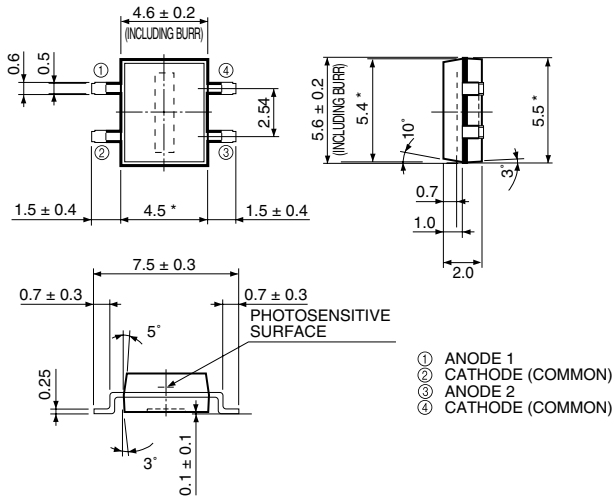

KPSDA0047EA

⑥ S5629-01/-02 (Surface mounting type)

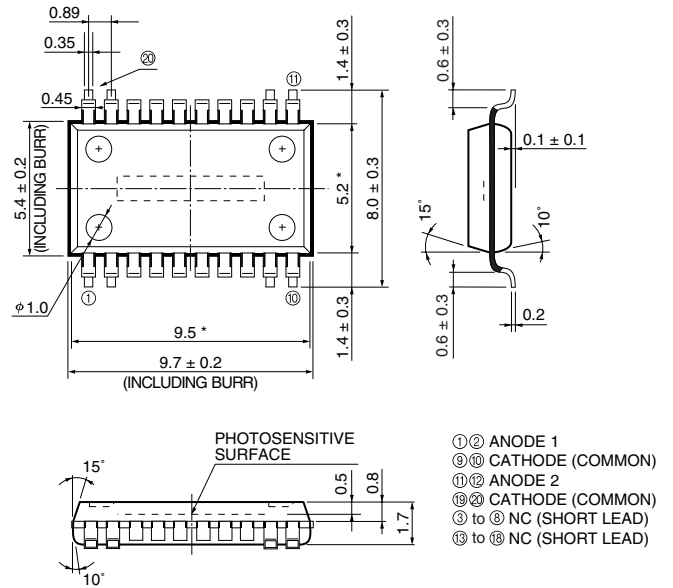

KPSDA0023EA

HAMAMATSU

Information furnished by HAMAMATSU is believed to be reliable. However, no responsibility is assumed for possible inaccuracies or omissions. Specifications are subject to change without notice. No patent rights are granted to any of the circuits described herein. ©2001 Hamamatsu Photonics K.K.

HAMAMATSU PHOTONICS K.K., Solid State Division

1126-1 Ichino-cho, Hamamatsu City, 435-8558 Japan, Telephone: (81) 053-434-3311, Fax: (81) 053-434-5184, <http://www.hamamatsu.com>

U.S.A.: Hamamatsu Corporation: 360 Foothill Road, P.O.Box 6910, Bridgewater, N.J. 08807-0910, U.S.A., Telephone: (1) 908-231-0960, Fax: (1) 908-231-1218

Germany: Hamamatsu Photonics Deutschland GmbH: Arzbergerstr. 10, D-82211 Herrsching am Ammersee, Germany, Telephone: (49) 08152-3750, Fax: (49) 08152-2658

France: Hamamatsu Photonics France S.A.R.L.: 8, Rue du Saule Trapu, Parc du Moulin de Massy, 91882 Massy Cedex, France, Telephone: 33-(1) 69 53 71 00, Fax: 33-(1) 69 53 71 10

United Kingdom: Hamamatsu Photonics UK Limited: 2 Howard Court, 10 Tewin Road, Welwyn Garden City, Hertfordshire AL7 1BW, United Kingdom, Telephone: (44) 1707-294888, Fax: (44) 1707-325777

North Europe: Hamamatsu Photonics Norden AB: Smidesvägen 12, SE-171 41 Solna, Sweden, Telephone: (46) 8-509-031-00, Fax: (46) 8-509-031-01

Italy: Hamamatsu Photonics Italia S.R.L.: Strada della Moia, 1/E, 20020 Arese, (Milano), Italy, Telephone: (39) 02-935-81-733, Fax: (39) 02-935-81-741